

CITY PLANS PANEL

THURSDAY 13th FEBRUARY 2025



Doing our best – to be the Best Council in the Best City



APPLICATION: 24/03842/FU

PROPOSAL: Full planning application for the demolition of the existing building and erection of a ground floor + 8/9/10 storey residential development; supporting infrastructure, ancillary facilities and landscaping.

**ADDRESS: 4 Canal Wharf
Holbeck
Leeds
LS11 5PS**





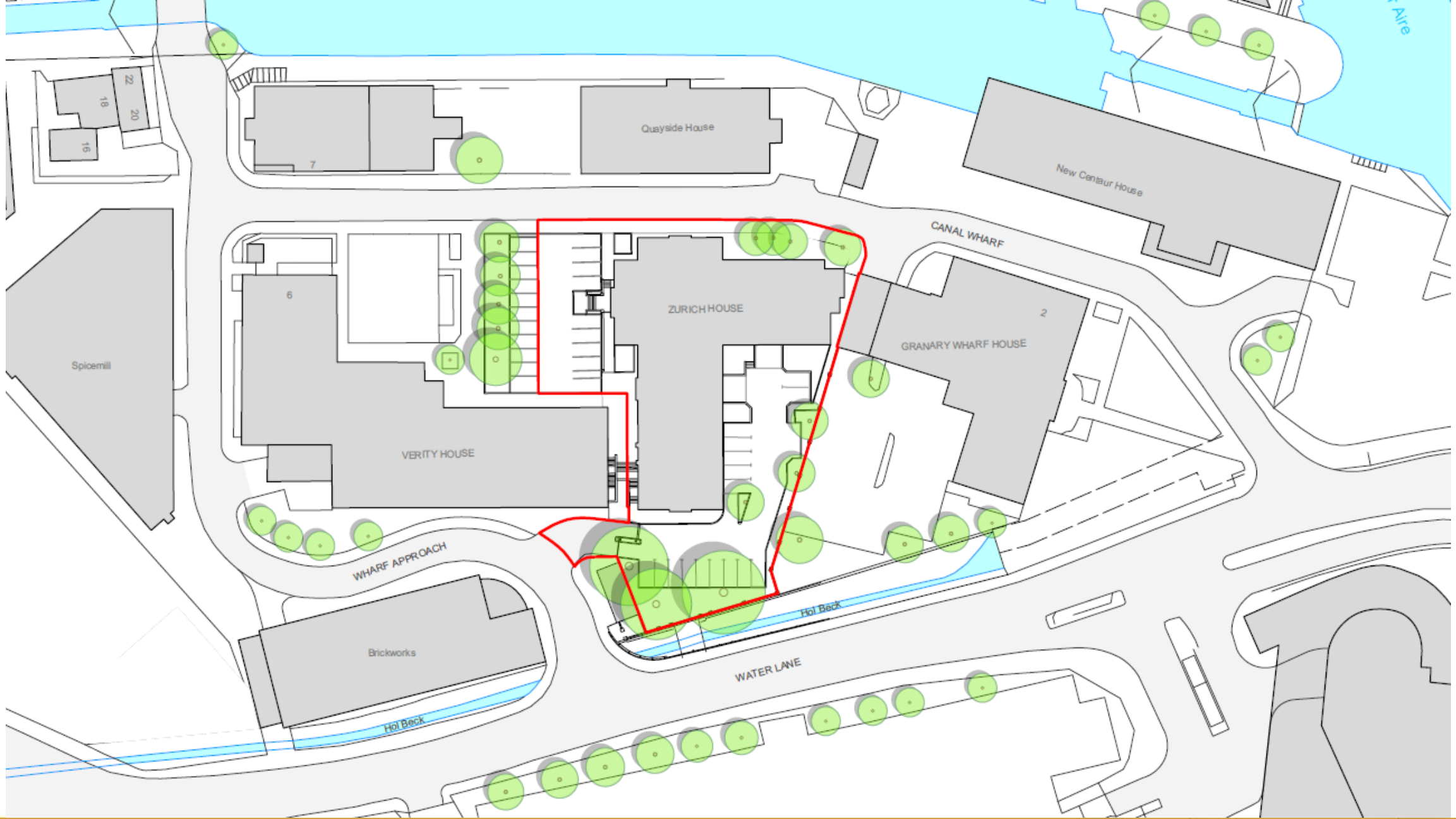

Aerial views



AERIAL VIEW LOOKING NORTH



AERIAL VIEW LOOKING EAST



AERIAL VIEW LOOKING WEST



AERIAL VIEW LOOKING SOUTH

Zurich House itself is a 2-storey building built in the mid 1990's that comprises 1,709m² (18,000ft²) of office floor space together with a semi basement that accommodates 27 parking spaces and further surface parking for 23 cars.

The building has a pitched slate roof with deep eaves and red brick elevations incorporating stone banding/detailing in an 'office vernacular' style typical of its age, similar to its immediate neighbours and those buildings on the northern side of Canal Wharf.

There is limited tree and shrub planting within the northern parking areas and within planters on the Canal Wharf frontage, the main group of three larger trees being located on the southern, Hol Beck boundary, adjacent to a single storey sub-station.



ZURICH HOUSE AND VERITY HOUSE



WHARF APPROACH LOOKING WEST



VEHICULAR ENTRANCE TO ZURICH HOUSE

SUB STATION



ZURICH HOUSE

BRIDGEWATER PLACE

Massing principles

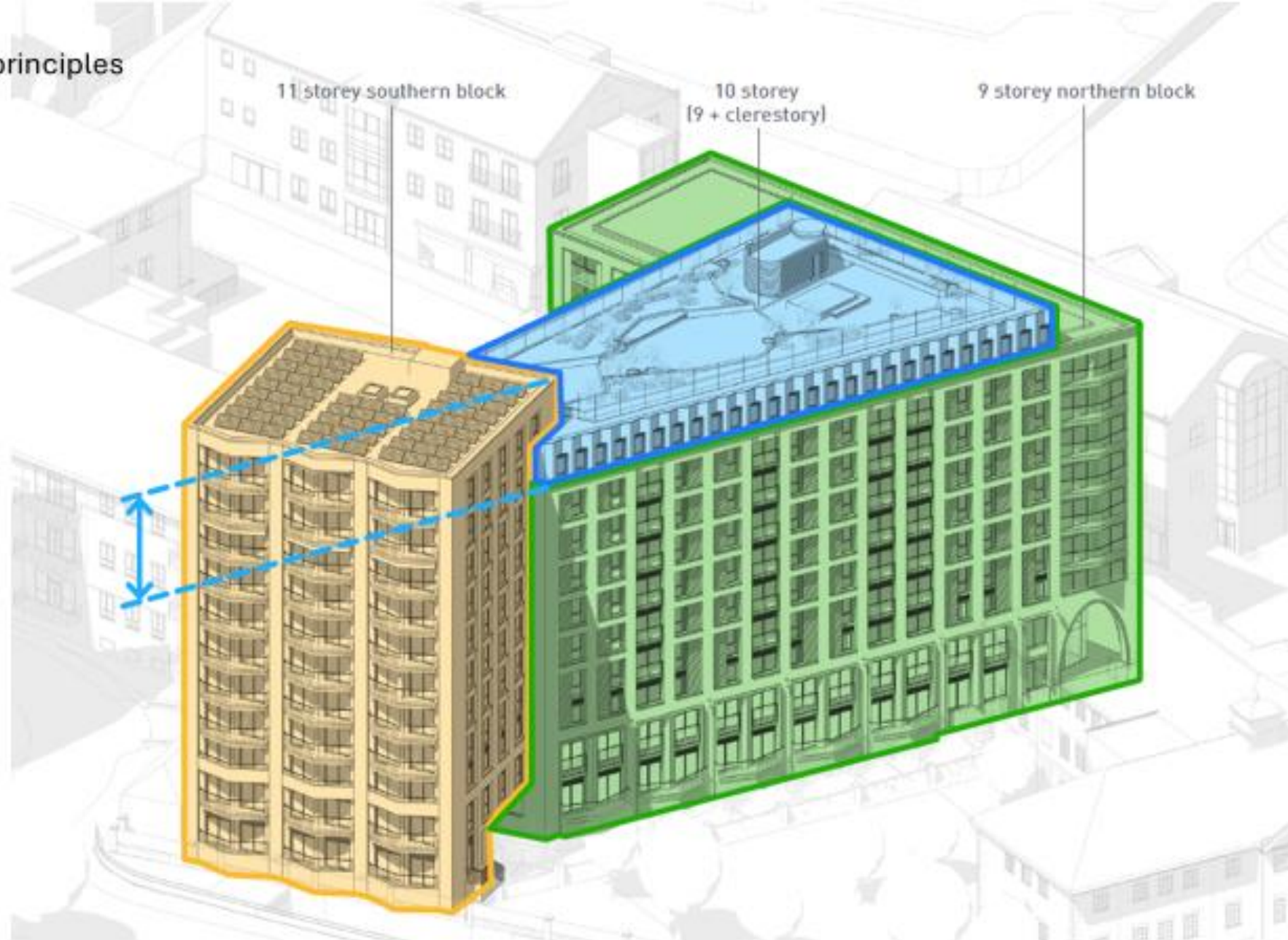





Mustard Wharf comparison

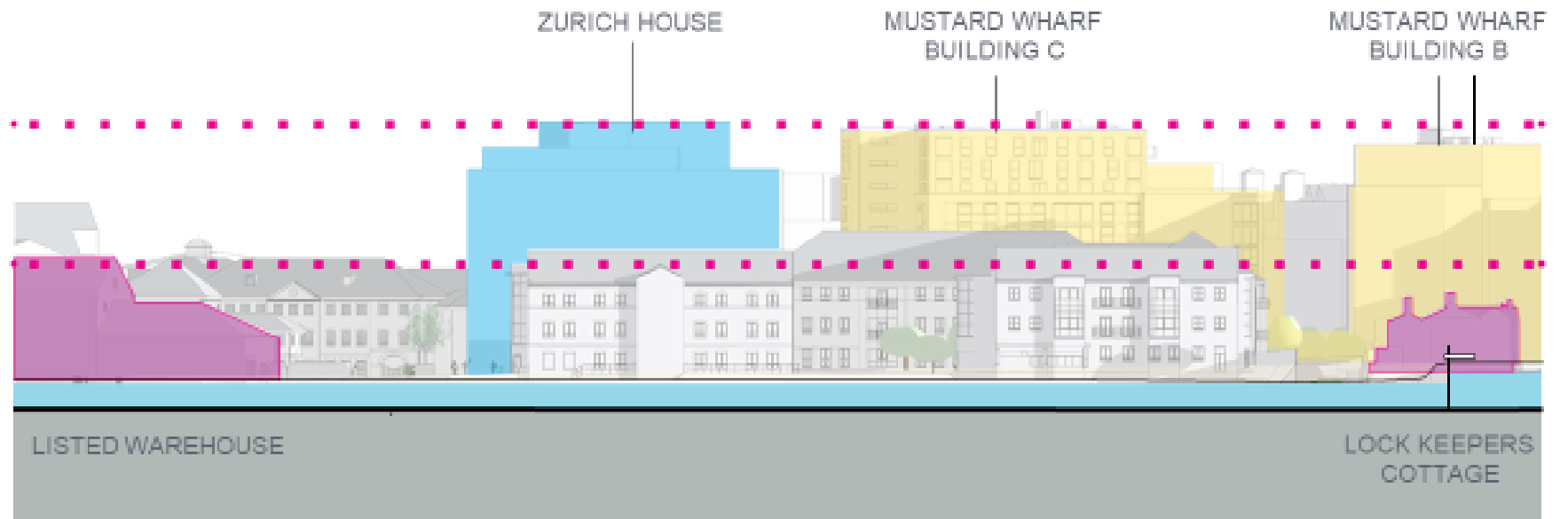

Building in context



CANAL WHARF (IN FRONT OF WATERMAN'S PLACE)



Building in context



EXISTING



PROPOSED

Building in context



EXISTING



PROPOSED

Building in context



EXISTING



PROPOSED

South Elevation



North Elevation

- ▼ 10th - 56.375 AOD
- ▼ 9th - 53.600 AOD
- ▼ 8th - 50.825 AOD
- ▼ 7th - 38.050 AOD
- ▼ 6th - 45.275 AOD
- ▼ 5th - 42.500 AOD
- ▼ 4th - 39.725 AOD
- ▼ 3rd - 36.950 AOD
- ▼ 2nd - 34.175 AOD
- ▼ 1st - 31.4 AOD
- ▼ G - 28.2 AOD



West Elevation



East Elevation



Ground Floor Plan



Floor Plans



Roof Plan



The Plinth



DOUBLE HEIGHT PLINTH



FULL ARCADED PEDESTRIAN ROUTE





01 - Northern Block base elevation (1:50 @ A3)

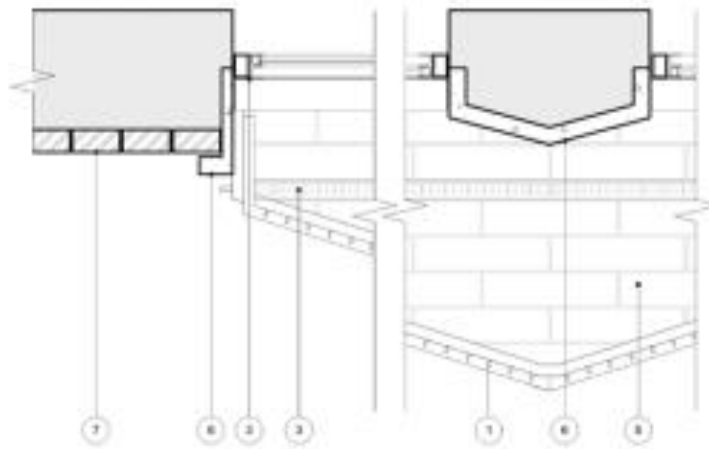

02 - Plan detail (1:20 @ A3)



East Elevation (1:500 @ A3)

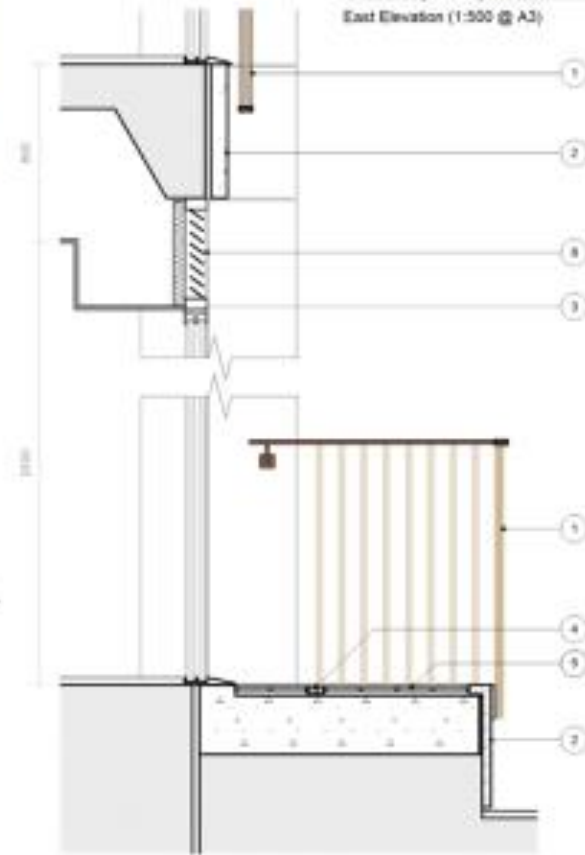

03 - Section detail (1:20 @ A3)

Materials Key

- 1 - PPC metal balustrade
- 2 - reconstructed stone fascia
- 3 - PPC aluminium window frames
- 4 - drainage channel
- 5 - ceramic tiles on thin bed adhesive
- 6 - reconstructed stone cladding
- 7 - red brick multi stock
- 8 - PPC micro louvre for interlockdown air

plinth detail

mid facade





01 - Northern Block middle elevation (1:50 @ A3)



East Elevation (1:500 @ A3)

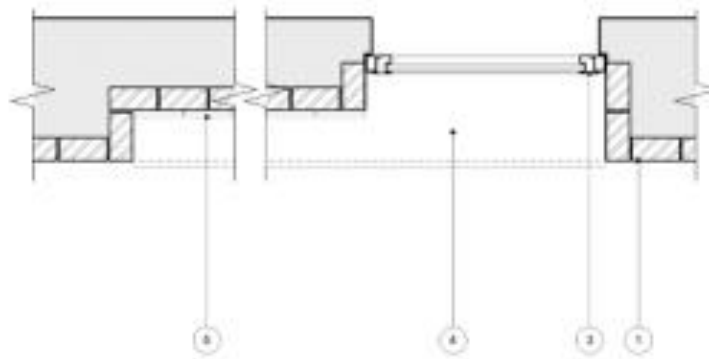

02 - Plan detail (1:20 @ A3)

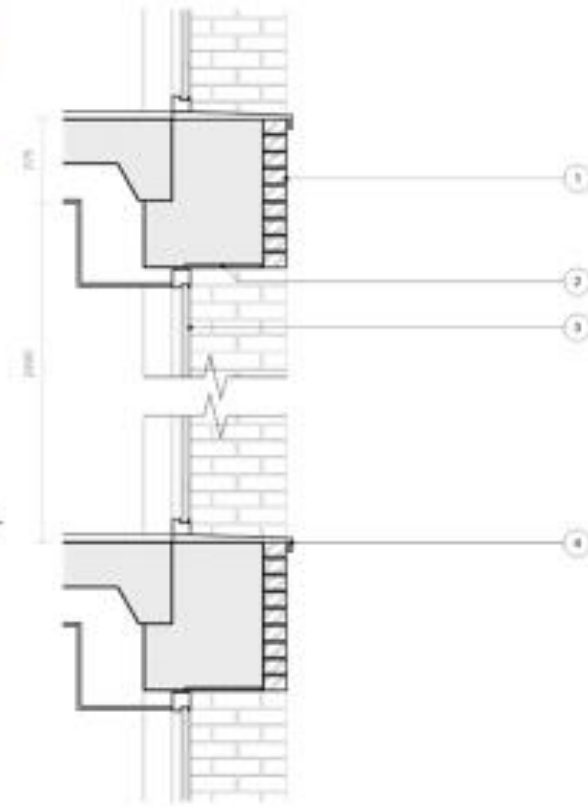

03 - Section detail (1:20 @ A3)

Materials Key

- 1 - red brick multi stock
- 2 - PPC aluminium sill to match window frames
- 3 - PPC aluminium window frame
- 4 - PPC aluminium window sill to match window frames
- 5 - Textured brickwork - every other course pulled forward by 30mm

mid-façade
detail

Clerestory



COPPER-BRONZE CLAD METAL CLERESTORY





01 - Northern Block top elevation (1:50 @ A3)

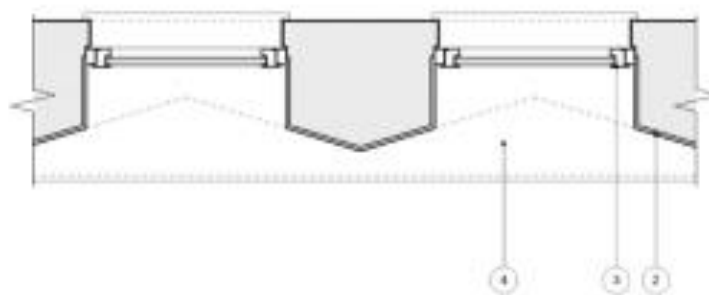

02 - Plan detail (1:20 @ A3)



East Elevation (1:500 @ A3)

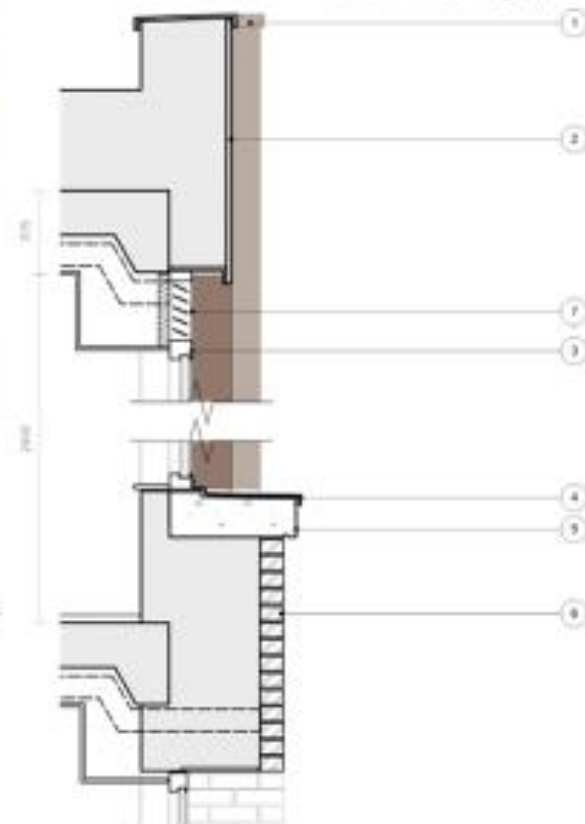

03 - Section detail (1:20 @ A3)

Materials Key

- 1 - copper bronze metal coping
- 2 - copper bronze metal cladding (rain screen)
- 3 - PPC aluminium window frame
- 4 - PPC aluminium sill to match window frames
- 5 - reconstituted stone coping
- 6 - red brick multi stock
- 7 - PPC micro louvre for intake/exhaust air

clerestorey
detail

Southern Facade





01 - Southern Block middle elevation (1:50 @ A3)



South Elevation (1:500 @ A3)

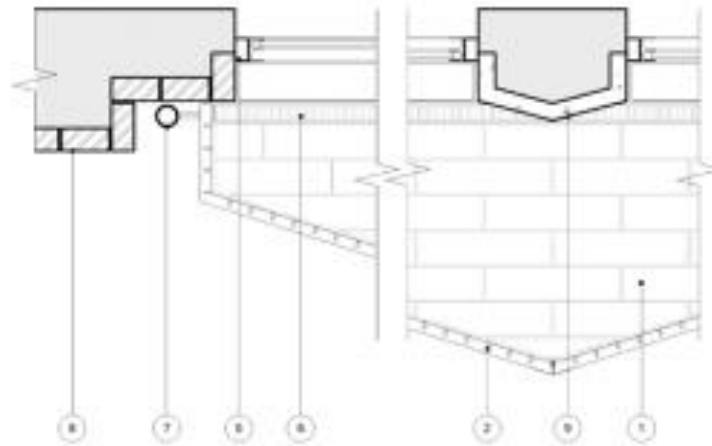

02 - Plan detail (1:20 @ A3)

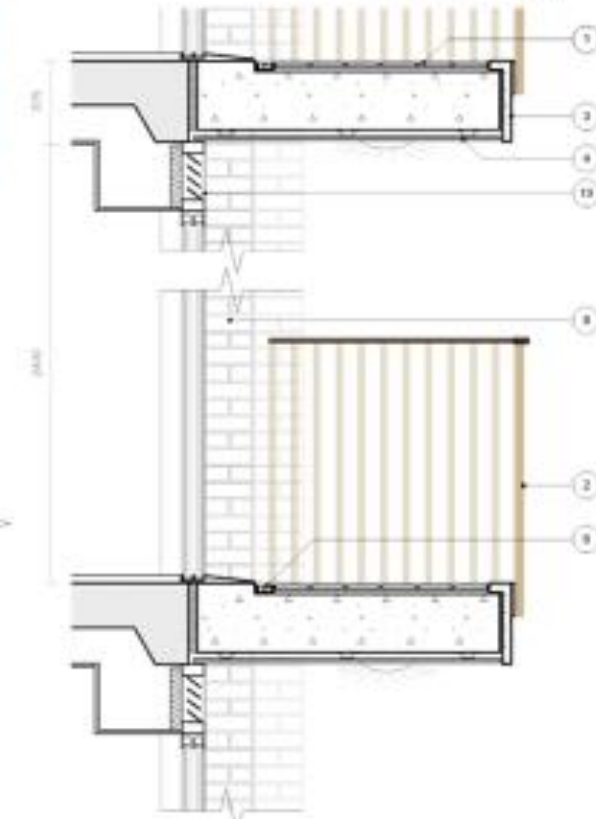

03 - Section detail (1:20 @ A3)

Materials Key

- 1 - ceramic tiles on thin bed adhesive
- 2 - PFC metal balustrade
- 3 - reconstituted stone fascia
- 4 - self finished composite board on metal stud
- 5 - PFC aluminium window frames
- 6 - drainage channel
- 7 - stainless steel FXP
- 8 - red brick multi stock
- 9 - reconstituted stone cladding
- 10 - PFC micro louvre for staircase/haust at

southern facade
detail

Main Entrance



THE PLINTH, ACTIVE FRONTAGE AND THE MAIN ENTRANCE

Aracde on western public footpath



Aracde on western public footpath



Eastern public footpath



Soft landscape precedent



Green Route



Potted plants to animate spaces



Terraced gardens



Undercroft Area - Framed Views



Evergreen Planting



Green Link Street



Pleached Trees

Hard landscape materials precedent



Arched paving to coincide with the buildings parabolic arch



Quality Concrete Paver to pedestrian routes



Yorkstone to pavements



Warm palette



Small format paver in key locations - building thresholds



Minimalist edging interventions to allow planting to blur the boundary



High quality paving in key areas

Play strategy



The play strategy centres on integrating incidental play opportunities within the soft landscape lining the link street, providing a natural link to traverse along this route. This approach ensures that these play areas are conveniently accessible, benefiting both the public and local residents alike.

Multiple elements have been carefully selected for their natural feel and simplistic design, creating spaces that encourage imaginative play despite the constraints of a smaller area. These elements not only enhance the aesthetic appeal of the surroundings but also provide meaningful recreational opportunities for everyone in the community to enjoy.

Additional educational interpretation for planting and habitats will be provided to introduce children to the value of nature.

- Key**
- Timber Stepping Logs
 - Stump Stack
 - Interactive signage
 - Finger maze
 - Talk tubes
 - Spinning Disk
 - Sculptural element



Timber stepping logs



Stump stack



Spinning Disk



Education interpretation signage



Talk tubes



Finger maze

Undercroft sections



1 UNDERCROFT SOUTH ELEVATION



2 UNDERCROFT NORTH ELEVATION

Undercroft combined public footpath/cycleway



Undercroft combined public footpath/cycleway – sequential views



Undercroft combined public footpath/cycleway – sequential views



Roof terrace



Roof terrace



Roof terrace - precedent images



Hard surfaces complement softer furniture



Thin formal decking to delineate activity areas



Large format porcelain tiles



Natural feel decking



Interface of porcelain with deck



Small format porcelain tiles

Roof terrace - precedent images



Varied textures and forms in pots



Evergreen structure with bursts of flowers



Areas of height to create enclosure



Seating integrated within planted areas



Hedges and shrub structure to create shelter



Views framed by vegetation

Roof terrace - play strategy

The play strategy on the rooftop closely mirrors the ground floor's intentions by seamlessly integrating incidental play opportunities where appropriate.

Numerous elements have been chosen for their natural feel and minimalist design, creating spaces that encourage imaginative and creative play. These selected components offer meaningful and engaging recreational opportunities for residents and their families.

The interventions are focussed on sensory play, with tactile and audio play items introduced throughout the roof terrace to provide playful elements throughout.

Additionally, educational materials and interpretative signs about planting and habitats will be provided. These resources aim to introduce children to the importance and value of nature, fostering an early appreciation and understanding of the natural world.



Educational totem



Chalkboard



Finger maze



Talk tubes



Bear stroking stone



On street delivery bay



refuse collection



waste and recycling storage at basement level



bins to street level via dedicated lift for collection



APPLICATION: 24/05830/OT

PROPOSAL: Outline planning application for erection of a university building (Use Class F1) with all matters reserved.

**ADDRESS: Land To The North Of Portland
Crescent And East Of The Rose Bowl
Building At Leeds Beckett University's City
Centre Campus**

Leeds

LS1 3HB







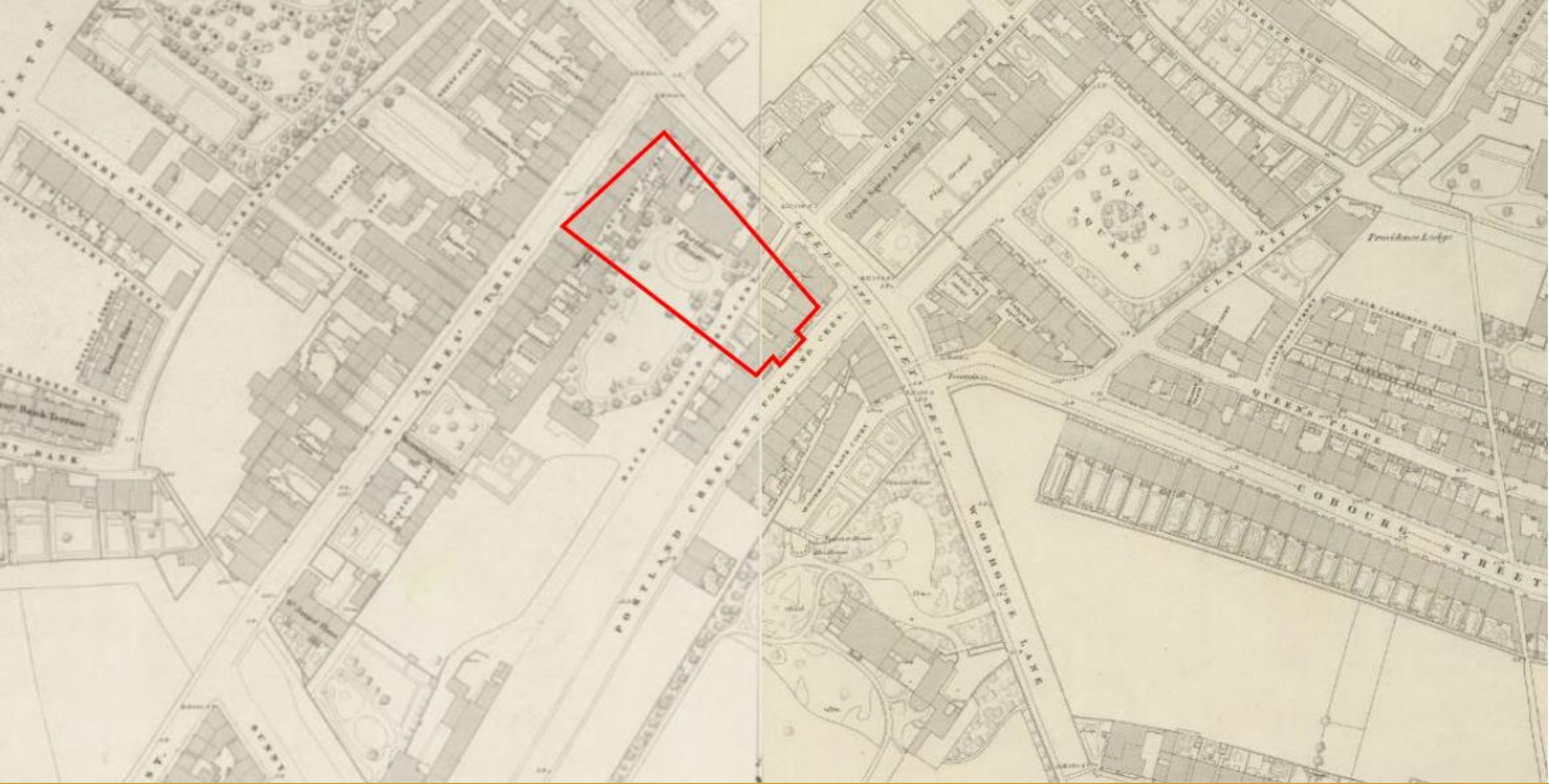



1913 Back Portland Crescent



1930 Back Portland Crescent



Portland Crescent 1930



1933



College of Commerce 1936

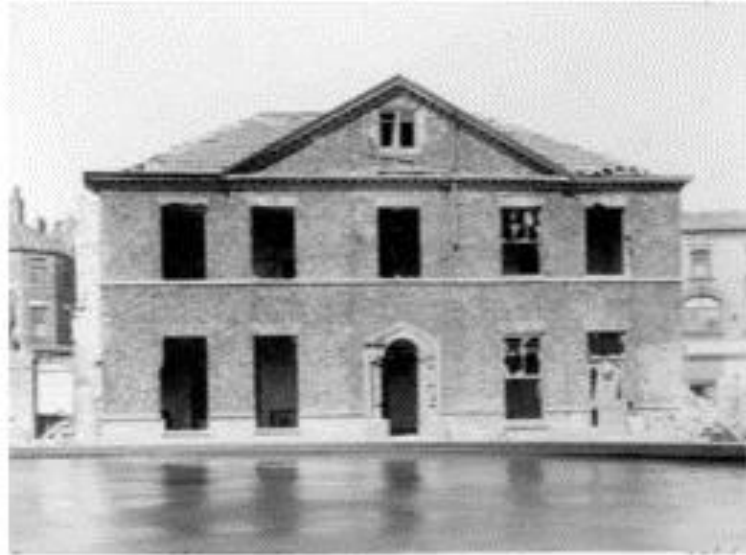

1942 Portland House

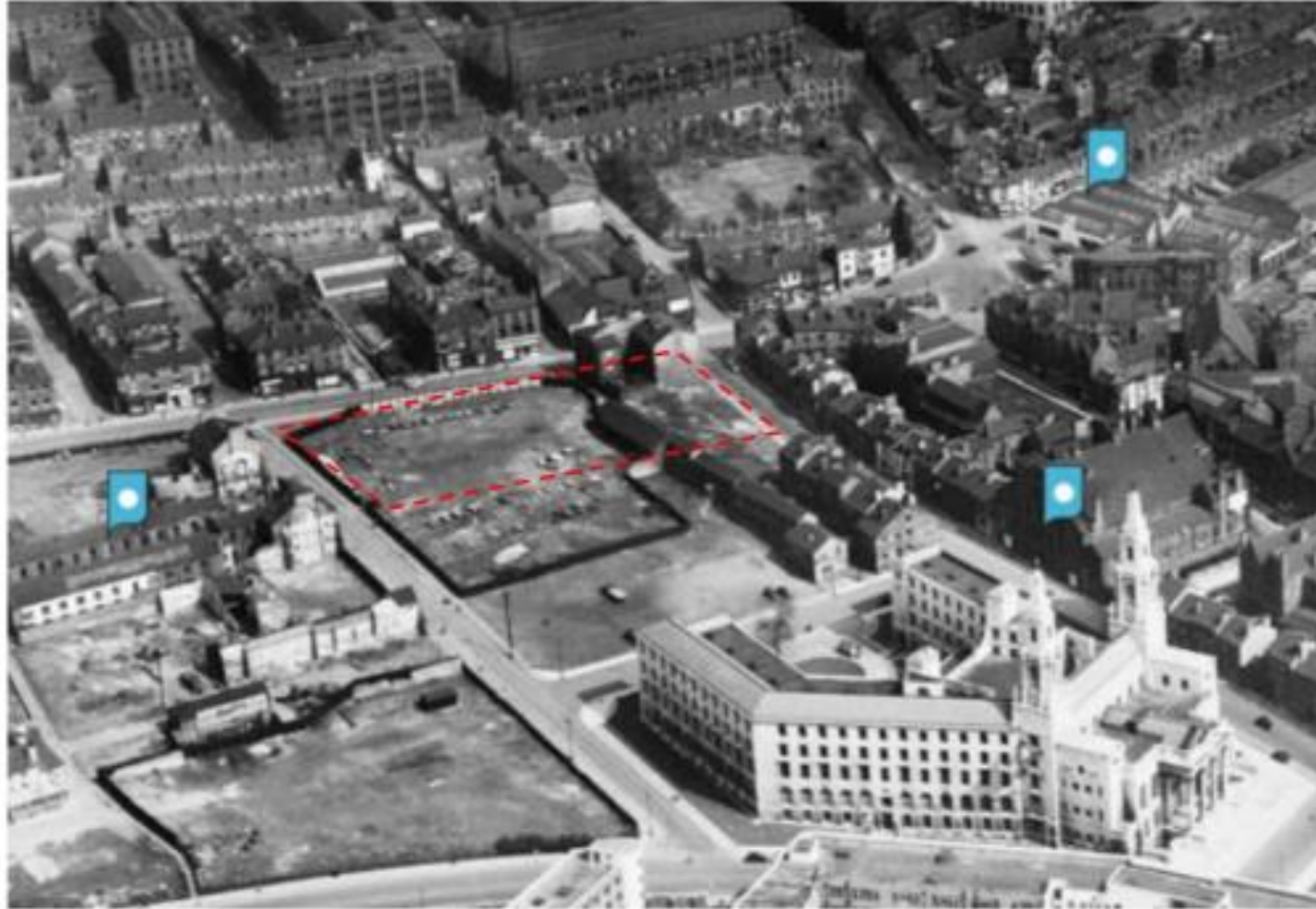

1948



1965



c.1999





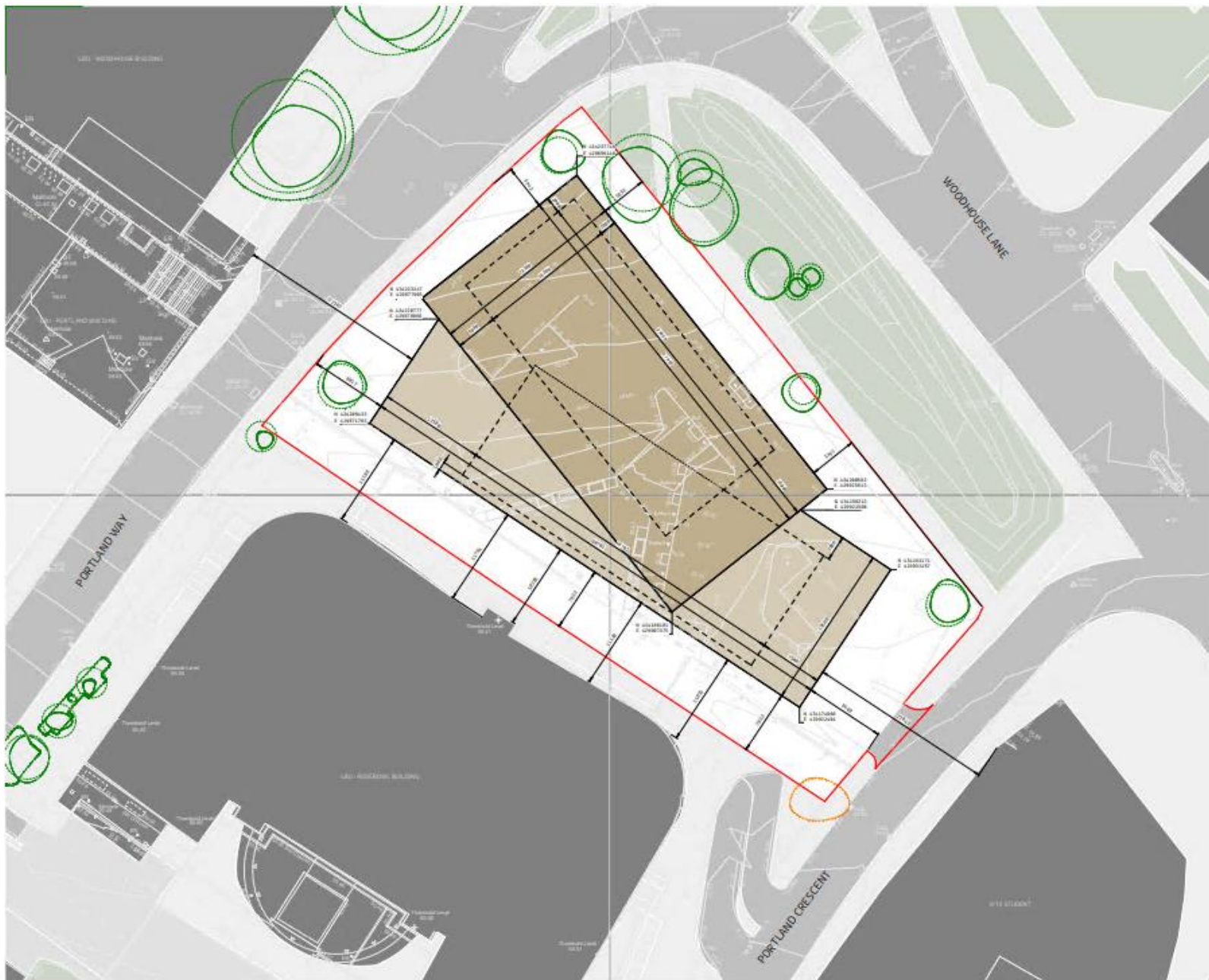

DATE	12/01/2010	12/01/2010
BY	FAULKNERBROWNS	FAULKNERBROWNS
FOR	LEEDS CITY COUNCIL	LEEDS CITY COUNCIL
PROJECT	LEEDS CITY COUNCIL	LEEDS CITY COUNCIL
LOCATION	LEEDS CITY COUNCIL	LEEDS CITY COUNCIL
SCALE	1:1000	1:1000
NO.	12/01/2010	12/01/2010

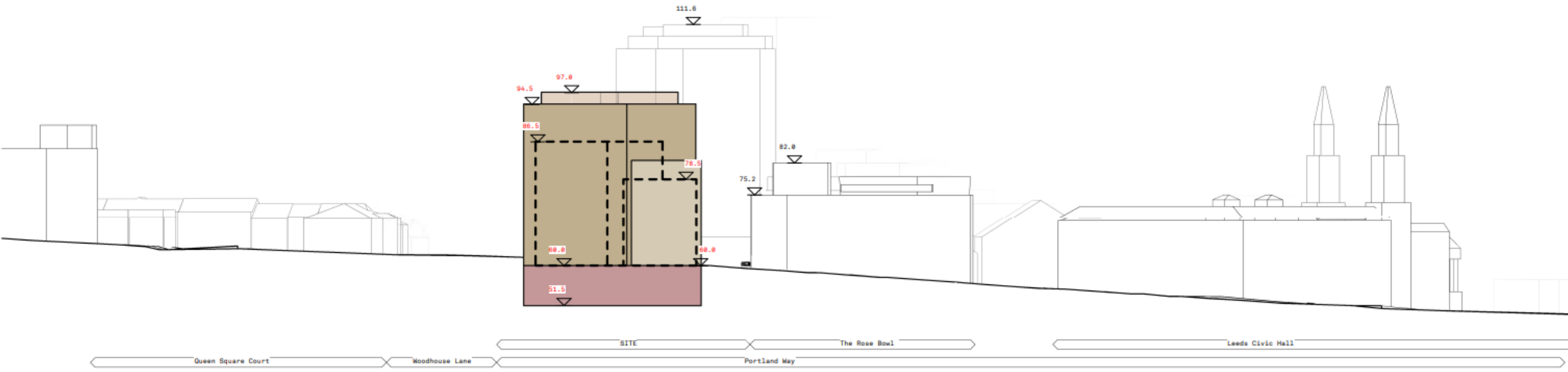

1 Portland Way Site Elevation - Parameter
1:500

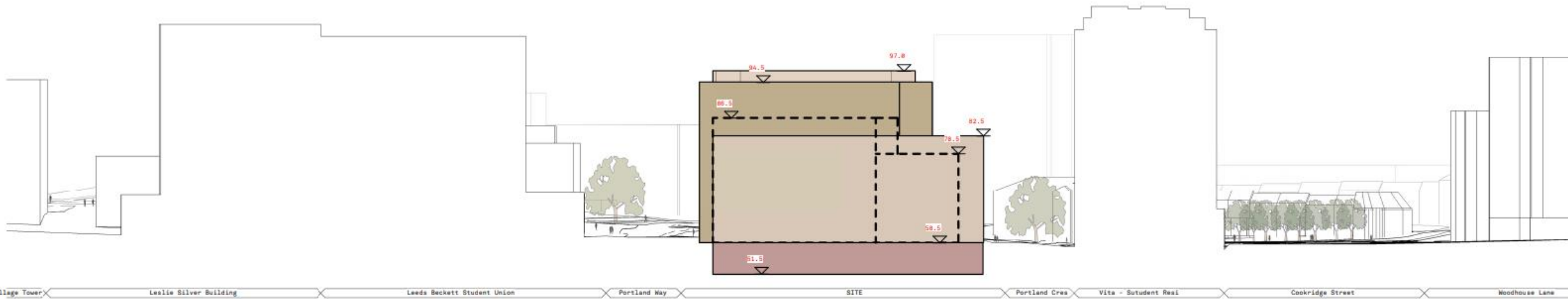

1 Rosebowl Site Elevation - Parameter
1:500

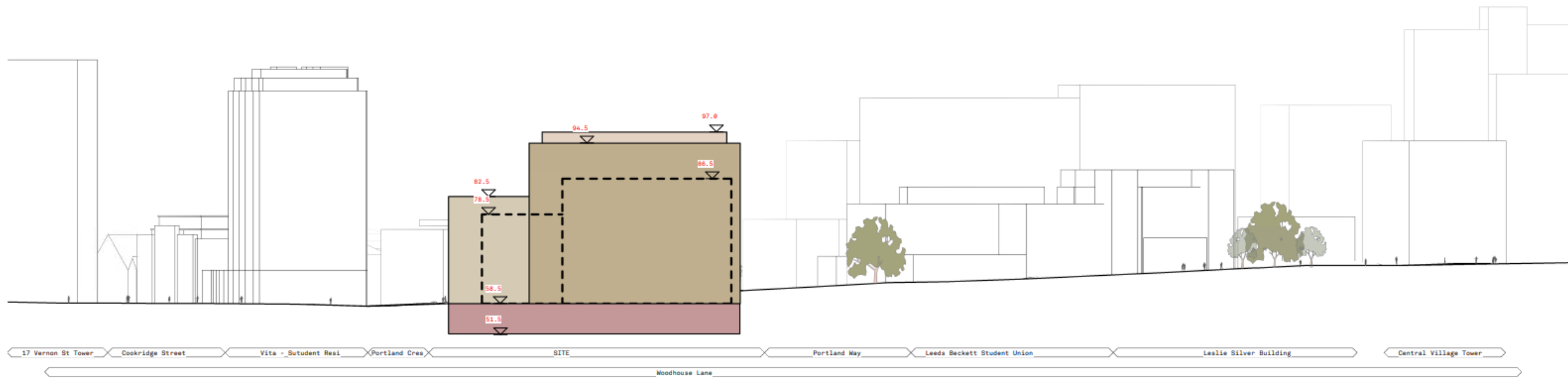

2 Woodhouse Lane Site Elevation - Parameter
1:500

















LEEDS BECKETT UNIVERSITY LAND ON WOODHOUSE LANE

Design Code
January 2025

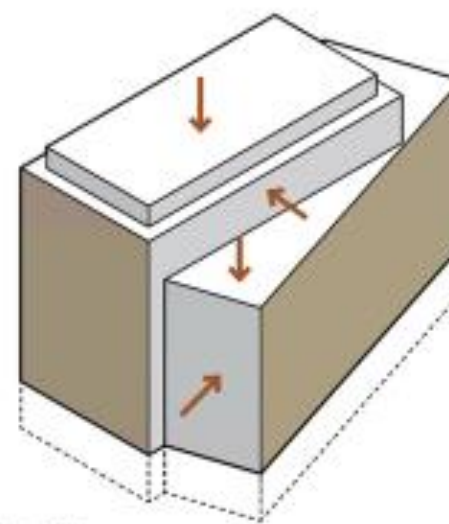

WEST ELEVATION (1)

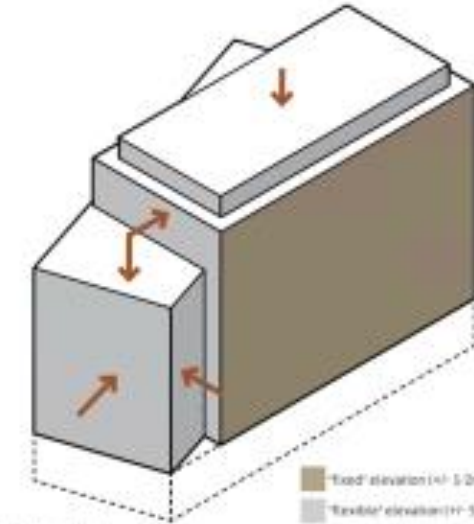

WEST ELEVATION (2)

■ 'fixed' elevation (+/- 5.0m)
■ 'flexible' elevation (+/- 5.7.5m)

WOODHOUSE LANE EAST		WOODHOUSE LANE EAST	
Is the building height within the permitted height?	✓	Is the building height within the permitted height?	✓
Is the building height within the permitted height?	✓	Is the building height within the permitted height?	✗
Is the building height within the permitted height?	✓	Is the building height within the permitted height?	✓
Is the building height within the permitted height?	✓	Is the building height within the permitted height?	✓
WOODHOUSE LANE WEST (DETACHED)		WOODHOUSE LANE WEST	
Is the building height within the permitted height?	✓	Is the building height within the permitted height?	✗
Is the building height within the permitted height?	✓	Is the building height within the permitted height?	✓
Is the building height within the permitted height?	✓	Is the building height within the permitted height?	✗
Is the building height within the permitted height?	✓	Is the building height within the permitted height?	✗







Illustrative ground floor







CITY PLANS PANEL

THURSDAY 13th FEBRUARY 2025

END OF PRESENTATION

